

MAX. OPERATING WEIGHT: 21675 kg (47785 lb) ENGINE POWER: 128 kW (172 hp)

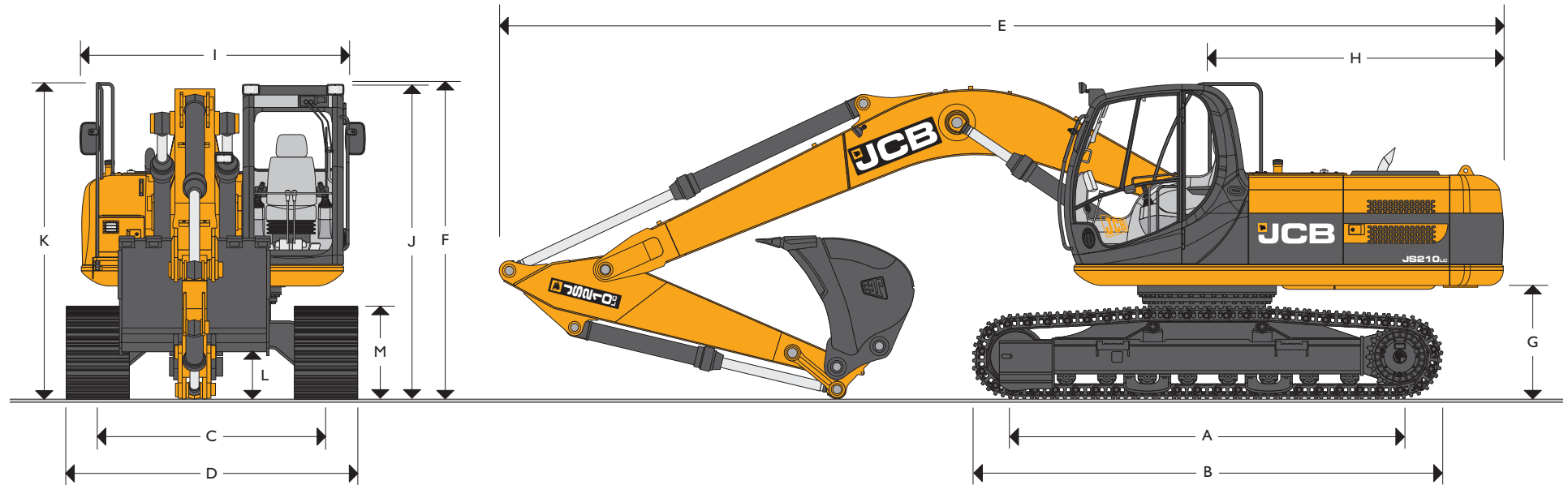

## STATIC DIMENSIONS

Dimensions in millimetres (ft-in)	LC
A Track length on ground	3660 (12-0)
B Undercarriage overall length	4460 (14-8)
C Track gauge	2170 (7-11)
D Width over tracks (600mm trackshoes)	2770 (9-1)
D Width over tracks (700mm trackshoes)	2870 (9-5)
D Width over tracks (800mm trackshoes)	2970 (9-9)
D Width over tracks (900mm trackshoes)	3070 (10-1)

Dipper lengths	1.91m (6ft 3in)	2.40m (7ft 10in)	3.0m (9ft 10in)
E Transport length with Monoboomb	9570 (31-5)	9560 (31-4)	9440 (31-0)
F Transport height with Monoboomb	3055 (10-0)	3060 (10-0)	3025 (9-11)

Dimensions in millimetres (ft-in)	LC
G Counterweight clearance	1066 (3-6)
H Tailswing radius	2825 (9-3)
I Width of superstructure	2549 (8-4)
J Height over cab	2946 (9-8)
K Height over grab rail	3025 (9-11)
L Ground clearance	486 (1-7)
M Track height	885 (2-11)



## ENGINE

<b>Model</b>	Isuzu 4HK1X. European Tier III emissions compliant.
<b>Type</b>	Water cooled, 4-stroke, 4-cylinder in-line, direct injection, turbocharged diesel.
<b>Nett power (ISO 3046- INF)</b>	128kW (172hp) at 2000rpm.
<b>Piston Displacement</b>	5.193 litres.
<b>Injection</b>	Electronic injection.
<b>Air Filtration</b>	Dry element with secondary safety element and in cab warning indicator.
<b>Cooling</b>	Water cooler via large capacity radiator.
<b>Starting system</b>	24 volt – 4.5kW.
<b>Batteries</b>	2 x 12 volt Heavy Duty.
<b>Alternator</b>	24 volt 40 amp.
<b>Refuelling pump</b>	Electric type.

## SWING SYSTEM

<b>Swing motor</b>	Axial piston.
<b>Swing brake</b>	Hydraulic braking plus automatic spring applied disc type parking brake.
<b>Final drive</b>	Planetary reduction.
<b>Swing speed</b>	12.9rpm.
<b>Swing gear</b>	Large diameter, internally toothed fully sealed grease bath lubricated.
<b>Swing lock</b>	Switchable brake in cab.

## UNDERCARRIAGE

<b>Carriage options</b>	LC-Long Carriage.
<b>Construction</b>	Fully welded, "X" frame type with central bellyguarding and track motor guards. Sloping sidemembers with dirt relief holes under top rollers.
<b>Recovery point</b>	Front and rear.
<b>Track type</b>	Sealed and greased.
<b>Track shoe options</b>	LC – 600mm (24in), 700mm (28in), 800mm (31.5in), 900mm (36in).
<b>Upper &amp; lower rollers</b>	Heat treated, sealed and lubricated.
<b>Track adjustment</b>	Grease cylinder type.
<b>Track idler</b>	Sealed and lubricated, with spring cushioned recoil.
	<b>LC</b>
<b>No. of track guides</b>	2 per side
<b>No. of lower rollers</b>	8 per side
<b>No. of upper rollers</b>	2 per side
<b>No. of track shoes</b>	49 per side

## HYDRAULICS

A variable flow load sensing system with flow on demand, variable power output and servo operated, multi-function open centre control. Machine auto warm up standard – maximises performance in cold conditions.

**Pumps**

<b>Main pumps</b>	2 variable displacement axial piston type.
<b>Maximum flow</b>	2 x 214 L/min (2 x 47 UK GPM).
<b>Servo pump</b>	Gear type.
<b>Maximum flow</b>	20 L/min (4.4 UK GPM).

**Control valve**

A combined four and five spool control valve with auxiliary service spool as standard. When required twin pump flow is combined to boom, dipper and bucket services for greater speed and efficiency.

**Relief valve settings**

<b>Boom/Arm/Bucket</b>	343 bar (4975 lbf/sq.in)
<b>Automatic power boost</b>	373 bar (5410 lbf/sq.in)
<b>Swing circuit</b>	289 bar (4190 lbf/sq.in)
<b>Travel circuit</b>	343 bar (4975 lbf/sq.in)
<b>Pilot control</b>	40 bar (580 lbf/sq.in)

A separate Cushion Control valve in the servo system provides cushioning of the boom and dipper spools selection and quick warm-up of the servo system.

**Hydraulic cylinders**

Double acting type, with bolt-up end caps and hardened steel bearing bushes. End cushioning is fitted as standard on boom, dipper and bucket rams.

Optional hose burst check valves available for boom and dipper rams.

**Filtration**

The hydraulic components are protected by the highest standard of filtration to ensure long hydraulic fluid and component life.

<b>In tank</b>	150 micron, suction strainer.
<b>Main return line</b>	10 micron, fibreform element.
<b>Plexus Bypass line</b>	1.5 micron, paper element.
<b>Pilot line</b>	10 micron, paper element.
<b>Hydraulic hammer return</b>	10 micron, reinforced microform element.

**Cooling**

Cooling is provided via a full return line air blast cooler as part of a single face cooling pack in conjunction with the engine water cooler.

## TRACK DRIVE

<b>Type</b>	Full hydrostatic, three speed with autoshift between high and medium speed.
<b>Travel motors</b>	Variable swash axial piston type, fully guarded within undercarriage frame.
<b>Final drive</b>	Planetary reduction, bolt-on sprockets.
<b>Service brake</b>	Hydraulic counter balance valve to prevent overspeeding on gradients.
<b>Park brake</b>	Disc type, spring applied, automatic hydraulic release.
<b>Gradeability</b>	70% (35 deg) continuous.
<b>Travel speed</b>	High – 5.6 km/h (3.4 mph). Mid – 3.3 km/h (2.1 mph). Low – 2.3 km/h (1.4 mph).
<b>Tractive effort</b>	202kN (19570 kgf, 43144 lbf).



## EXCAVATOR END

Monoboom available along with a choice of dipper lengths to suit the requirements of reach, dig-depth, loadover height, tearout and site versatility. Reserve strength is built into the fully welded structures for hydraulic hammer and other arduous operations. Fabricated bucket tipping links are provided with a choice of lift points.

Strong, durable construction, large cross sections and multi plate fabrications to withstand high stress applications.

The 5.7m (18ft 8in) boom is designed to ensure the optimum digging envelope when matched with the three dipper lengths.

Low maintenance bronze alloy bushes with graphite plugs are fitted to boom base and boom to dipper pivots resulting in 1000 hour greasing intervals at these points.

## CAB

Excellent digging, loading and positioning visibility results from the careful design of front, side and roof lights. All screens are tinted to improve in cab conditions.

Fully opening front screen is very smooth to operate and as the lower screen is stored within the top screen frame it makes complete front screen opening easy, fast and convenient.

Fresh air ventilation available from opening door window, opening slot in front screen and fully opening front screen.

Parallelogram wash wiper for upper screen ensuring good wiped area for maximum visibility. Wiper motor is fitted in the left hand side of the roof screen so as not to affect bucket visibility when loading. Optional lower screen wiper available.

Fresh air ventilation and heater with windscreen demister. Infinitely variable blower speed, temperature and recirculation control.

Optional climate control. Fully adjustable deluxe suspension seat with arm rest adjustment and backrest recline. Optional radio with digital tuner fitted into the roof lining for maximum protection. Conveniently placed radio mute button incorporated into lower console. 12v power point and mobile phone holder built into the right hand console. Courtesy light can be operated from ground level and is illuminated for five minutes or until switched off improving operator access at night. Cab mounted roller blind protects operator from sun's glare through front or top screens.

## AMS – ADVANCED MANAGEMENT SYSTEM

Four selectable working modes link the operators control movements with the engine and hydraulic systems to maximise productivity and efficiency.

### A (Auto)

Up to 100% engine power and 100% flow. Gives variable power and speed depending on the operator's input, matching the demand for output and efficiency to the job. Power boost is automatically activated in this mode should hard conditions be encountered. Auto idle cuts in after a period of inactivity (between 5 and 30 seconds as set by the operator)

### E (Economy)

80% engine power: 95% of hydraulic flow maximises economy while maintaining excellent output.

### P (Precision)

55% engine power: 90% of hydraulic flow for fine control of grading operations.

### L (Lifting)

55% engine power: 63% of hydraulic flow with permanent power boost for maximum lifting power and control.

The Auto mode allows the AMS processor to select the optimum operational performance to match the demands of the job while the three alternative modes give precise matching of application when specific tasks are undertaken.

The adjustable position monitor mounted on the front right hand pillar of the cab gives the operator a constant read out of mode, tracking range, operating temperature and a host of other information, while retaining excellent visibility of the monitor and the job being carried out.

The required flow for hammer applications can be set and stored in the AMS memory and is automatically activated whenever the hammer pedal is depressed.

A maintenance indicator warns of imminent service needs, and all servicing and basic checks can be carried out using only the in cab display.

## CONTROLS

### Excavator

#### Tracks

All servo lever operated to ISO control pattern, independently adjustable to the seat.

Individually servo operated by foot pedal or hand lever.

Speed selection via joystick button.

Via servo operated foot pedal.

#### Auxiliary

#### Control isolation

Via gate lock lever at cab entrance or panel switch.

#### Engine speed

Dial type throttle control plus servo lever mounted one-touch idle control or separate selectable auto-idle with adjustable time delay using AMS.

#### Engine stop

Ignition key operated and separate shut-down button.

#### Horn

Operated via servo lever mounted button.



**SERVICE CAPACITIES**

Fuel tank	litres (UK gal)	343 (75.5)
Engine coolant	litres (UK gal)	25.5 (5.61)
Engine oil	litres (UK gal)	21.5 (4.7)
Swing reduction gear	litres (UK gal)	5.0 (1.1)
Track reduction gear (each side)	litres (UK gal)	4.7 (1.0)
Hydraulic system	litres (UK gal)	200 (44)
Hydraulic tank	litres (UK gal)	120 (26.4)

**WEIGHTS AND GROUND BEARING PRESSURES**

Figures include 1.14cu.m. bucket (760kg (1675lbs), operator, full fuel tank, 600mm track shoes and 2.4m dipper.

	JS210 Mono			
	Machine weight		Ground bearing pressure	
	kg	lbs	kg/cm	lb/sq ft
600mm shoes	21090	46495	0.39	5.55
700mm shoes	21355	47080	0.34	4.83
800mm shoes	21625	47675	0.30	4.30
900mm shoes	21675	47785	0.27	3.85

**GENERAL PURPOSE EXCAVATOR BUCKETS**

All buckets are JCB – Escó type fully welded steel, with sealed, hardened steel pivot pins and replaceable wear parts.

Max Width	Capacity (SAE heaped)	Weight
600mm (24in.)	0.40cu.m (0.52cu.yd)	484kg (1067lb)
900mm (36in.)	0.71 cu.m (0.93cu.yd)	595kg (1312lb)
1000mm (39in.)	0.81 cu.m (1.06cu.yd)	627kg (1382lb)
1200mm (47in.)	1.03cu.m (1.35cu.yd)	705kg (1555lb)
1350mm (53in.)	1.05cu.m (1.37cu.yd)	679kg (1497lb)
1450mm (57in.)	1.14cu.m (1.49cu.yd)	720kg (1588lb)
1500mm (59in.)	1.19cu.m (1.56cu.yd)	734kg (1618lb)

**STANDARD / OPTIONAL EQUIPMENT**

**Standard Equipment:** Engine fan guard; Cold start pre-heat; Auto engine warm up; Double element air cleaner; Electric refuelling pump; Heavy duty alternator; Electrics isolator; Heavy duty batteries; Cab & engine soundproofing; Cab heater & screen demister; Tinted glass; Interior light; Coat hook; Cigarette lighter; Ashtray; Operator’s storage shelf; Removable floor mat; Windscreen wash/wipe; Plug-in power socket; Automatic power boost; Auto-idle; One-touch engine speed control; Hydraulic cushion control; Boom/swing priority switch; Plexus hydraulic oil filtration; HSP pressure test points; Auxiliary pipework mounting brackets; Work lights – boom & mainframe mounted; Undercarriage belly guarding; Upper structure under covers; Swing system cover; Twin track guides; External mirrors; Handrail & non slip walk ways; Quick connect engine oil drain pipe; Front screen blind; Quick connect fuel tank drain pipe; Hinged engine under cover; Remote filter system.

**Optional Equipment:** Hose burst check valves & overload warning system; Tipping link mounted lift points; General purpose buckets; Ditch/grading buckets; Quickhitch buckets; Hydraulic hammers; Auxiliary pipework (full and low flow); Climate control; Cab mounted & rear work lights; Rotating beacon; Rain guard; Biodegradeable oil; Air suspension seat with heated pad and lumbar support adjustment; lower screen wiper; Radio; High and low temperature hydraulic oil option.





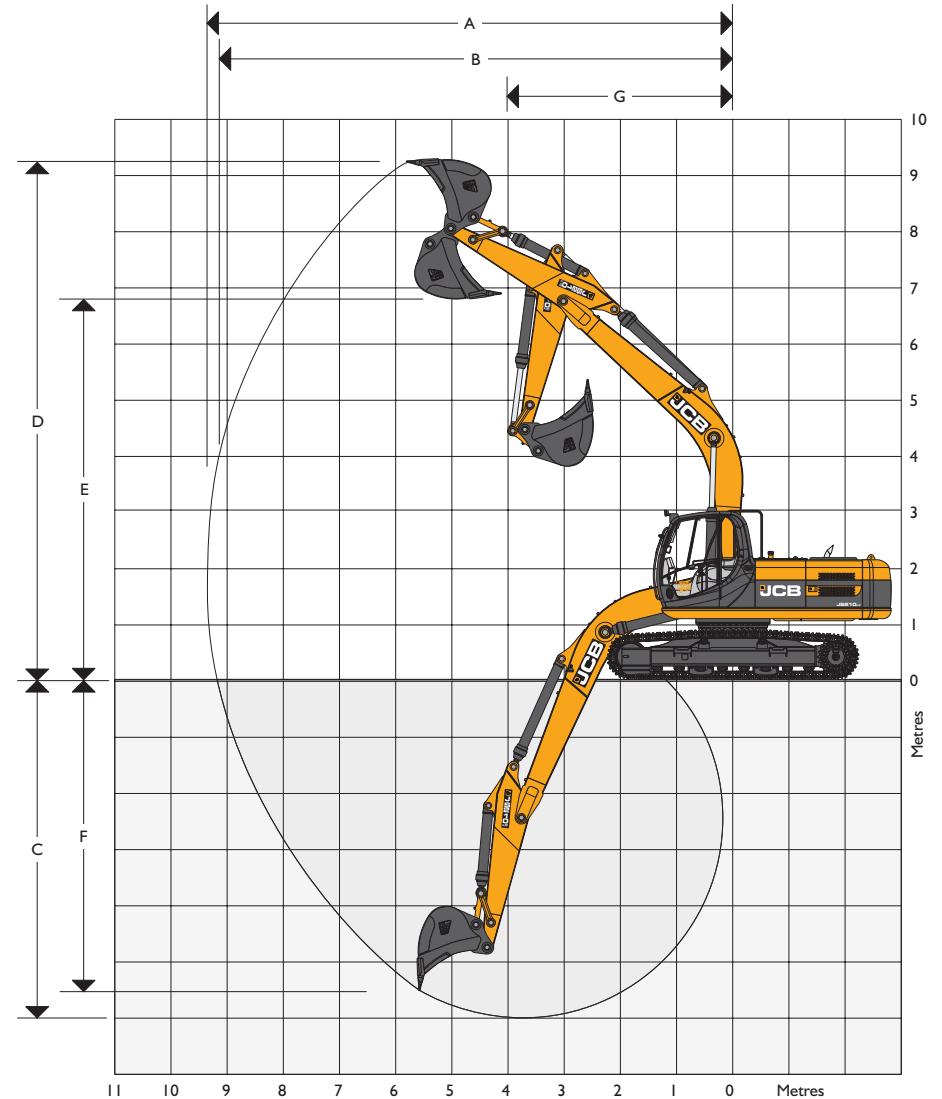





## WORKING RANGE

Boom length 5.70m (18ft 8in)		1.91m (6ft 3in)	2.40m (7ft 10in)	3.00m (9ft 10in)	
<b>Dipper length</b>					
<b>A</b>	Maximum digging reach	m (ft-in)	8.89 (29-2)	9.34 (30-8)	9.87 (32-5)
<b>B</b>	Maximum digging reach (on ground)	m (ft-in)	8.70 (28-7)	9.16 (30-1)	9.70 (31-10)
<b>C</b>	Maximum digging depth	m (ft-in)	5.53 (18-2)	6.02 (19-9)	6.60 (21-8)
<b>D</b>	Maximum digging height	m (ft-in)	8.95 (29-4)	9.20 (30-2)	9.40 (30-10)
<b>E</b>	Maximum dumping height	m (ft-in)	6.31 (20-8)	6.53 (21-5)	6.75 (22-2)
<b>F</b>	Maximum vertical wall cut depth	m (ft-in)	4.90 (16-1)	5.47 (17-11)	6.07 (19-11)
<b>G</b>	Minimum swing radius	m (ft-in)	3.76 (12-4)	3.71 (12-2)	3.60 (11-10)
	Bucket rotation	deg.	183°	183°	183°
	Dipper tearout (ISO 6015)	kgf (lbf)	13450 (29650)	11560 (25485)	9590 (21142)
	Dipper tearout with boost (ISO 6015)	kgf (lbf)	14610 (32210)	12550 (27670)	10410 (22950)
	Bucket tearout (ISO 6015)	kgf (lbf)	14550 (32080)	14550 (32080)	14550 (32080)
	Bucket tearout with boost (ISO 6015)	kgf (lbf)	15800 (34835)	15800 (34835)	15800 (34835)













## LIFT CAPACITIES – Dipper length: 1.9m, Monoboom 5.7m, Trackshoes: 700mm, No bucket.

**JS210 LC MONO**

Reach	3m (9ft 10in)		4.5m (14ft 9in)		6m (19ft 8in)		7.5m (24ft 7in)		Max. Reach		Max. Reach
											
Load Point Ht.	kg	kg	kg	kg	kg	kg	kg	kg	kg	kg	mm
6.0m (19.8ft)					6380*	4990			5720*	4850	6105
4.5m (14.9ft)			8020*	7450	6720*	4890			5700*	3950	6907
3.0m (9.10ft)			9870*	6960	7470*	4700			5820	3550	7318
1.5m (4.11ft)			11210*	6610	7660	4520			5640	3420	7406
0m			11510*	6500	7540	4430			5840	3520	7182
- 1.5m (- 4.11ft)	13010*	12440	11040*	6520	7540	4420			6570	3920	6614
- 3.0m (- 9.10ft)	12760*	12620	9650*	6660					7600*	4970	5596
- 4.5m (- 14.9ft)											

## LIFT CAPACITIES – Dipper length: 2.4m, Monoboom 5.7m, Trackshoes: 700mm, No bucket.

**JS210 LC MONO**

Reach	3m (9ft 10in)		4.5m (14ft 9in)		6m (19ft 8in)		7.5m (24ft 7in)		Max. Reach		Max. Reach
											
Load Point Ht.	kg	kg	kg	kg	kg	kg	kg	kg	kg	kg	mm
7.5m (24.7ft)									5230*	5230*	5547
6.0m (19.8ft)					5810*	5080			4790*	4180	6767
4.5m (14.9ft)			7330*	7330*	6290*	4950			4690*	3520	7497
3.0m (9.10ft)			9230*	7090	7110*	4740	5630	3450	4800*	3200	7878
1.5m (4.11ft)			10820*	6690	7680	4550	5540	3360	5080	3090	7959
0m			11480*	6510	7540	4420	5470	3300	5230	3170	7751
- 1.5m (- 4.11ft)	10850*	10850*	11300*	6490	7500	4380			5760	3460	7229
- 3.0m (- 9.10ft)	14090*	12470	10270*	6580	7560*	4460			6980*	4190	6313
- 4.5m (- 14.9ft)			7500*	6850					6850*	6320	4777



Lift capacity front and rear.













Lift capacity full circle.

- Notes:**
1. For lifting capacity including bucket, subtract total weight of bucket or bucket and quickhitch from above values.
  2. Lifting capacities are based on ISO 10567, that is: 75% of minimum tipping load or 87% of hydraulic lift capacity, whichever is the less. Lifting capacities marked\* are based on hydraulic capacity.
  3. Lift capacities assume that the machine is on firm, level ground.
  4. Lift capacities may be limited by local regulations. Please refer to your dealer.

## LIFT CAPACITIES – Dipper length: 3.0m, Monoboom 5.7m, Trackshoes: 700mm, No bucket.

**JS210 LC MONO**

Reach	3m (9ft 10in)		4.5m (14ft 9in)		6m (19ft 8in)		7.5m (24ft 7in)		Max. Reach		Max. Reach
	 kg	 kg	 kg	 kg	 kg	 kg	 kg	 kg	 kg	 kg	
Load Point Ht.	kg	kg	kg	kg	kg	kg	kg	kg	kg	kg	mm
7.5m (24.7ft)					4350*	4350*			3440*	3440*	6285
6.0m (19.8ft)					5170*	5170			3210*	3210*	7382
4.5m (14.9ft)					5740*	5020	5190*	3570	3160*	3160*	8056
3.0m (9.10ft)	11580*	11580*	8380*	7240	6630*	4800	5670	3470	3230*	2920	8411
1.5m (4.11ft)											
0m	6400*	6400*	10200*	6780	7560*	4570	5540	3360	3430*	2820	8488
- 1.5m (- 4.11ft)	10510*	10510*	11410*	6430	7450	4340	5420	3250	4470*	3090	7807
- 3.0m (- 9.10ft)	15320*	12250	10770*	6470	7480	4360			5790*	3620	6969
- 4.5m (- 14.9ft)	12460*	12460*	8920*	6650					6760*	4930	5619



Lift capacity front and rear.



Lift capacity full circle.

- Notes:**
1. For lifting capacity including bucket, subtract total weight of bucket or bucket and quickhitch from above values.
  2. Lifting capacities are based on ISO 10567, that is: 75% of minimum tipping load or 87% of hydraulic lift capacity, whichever is the less. Lifting capacities marked\* are based on hydraulic capacity.
  3. Lift capacities assume that the machine is on firm, level ground.
  4. Lift capacities may be limited by local regulations. Please refer to your dealer.

## A GLOBAL COMMITMENT TO QUALITY

JCB's total commitment to its products and customers has helped it grow from a one-man business into Britain's largest privately owned manufacturer of backhoe loaders, crawler excavators, wheeled excavators, telescopic handlers, wheeled loaders, dump trucks, rough terrain fork lifts, industrial fork lifts, mini/midi excavators, skid steer loaders and tractors.

By making constant and massive investments in the latest production technology, the JCB factories have become some of the most advanced in Europe.

By leading the field in innovative research and design, extensive testing and stringent quality control, JCB machines have become renowned all over the world for performance, value and reliability.

And with a global sales and service network of over 400 distributors and agents, the company exports over 70% of its production to all five continents.

Through setting the standards by which others are judged, JCB has become one of Britain's most impressive success stories.

